

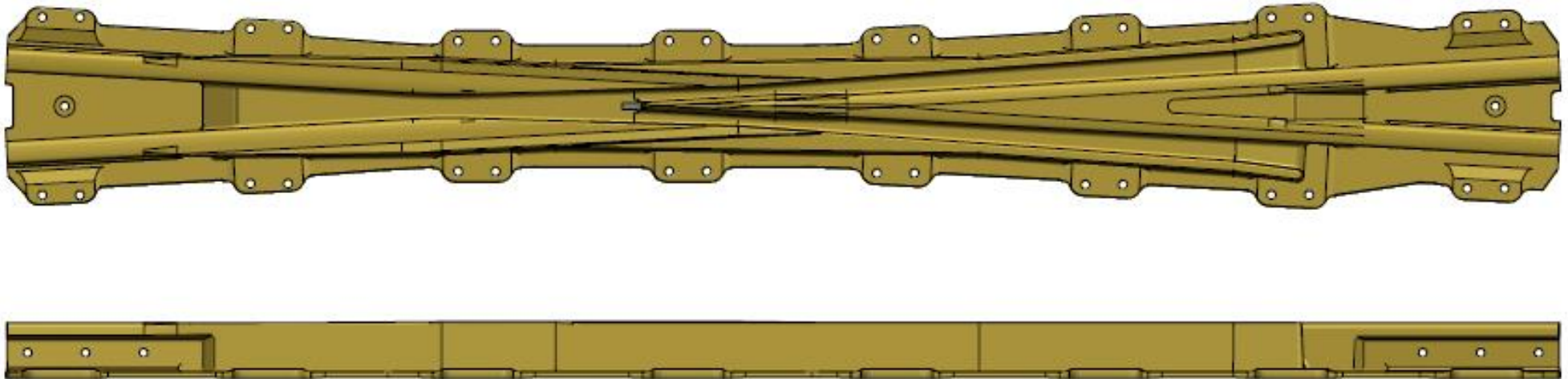

Machining operation of railway frog

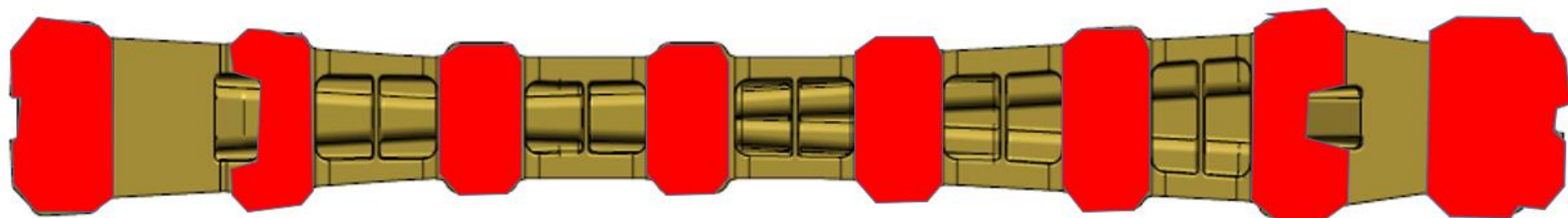

Sole surfacing operation



Surfacing operation on planite

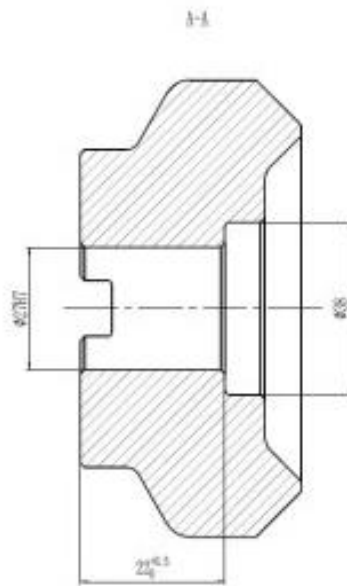
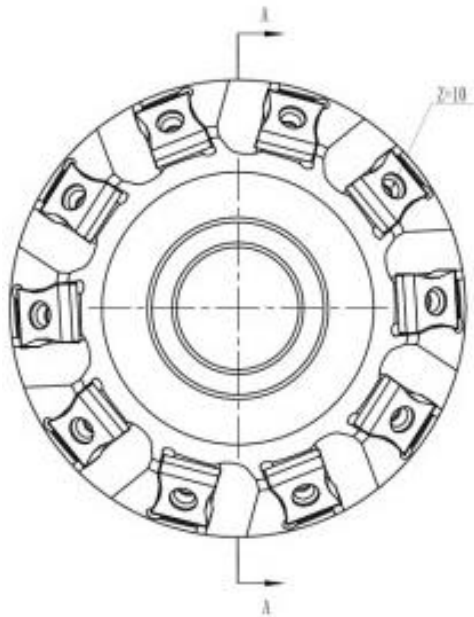
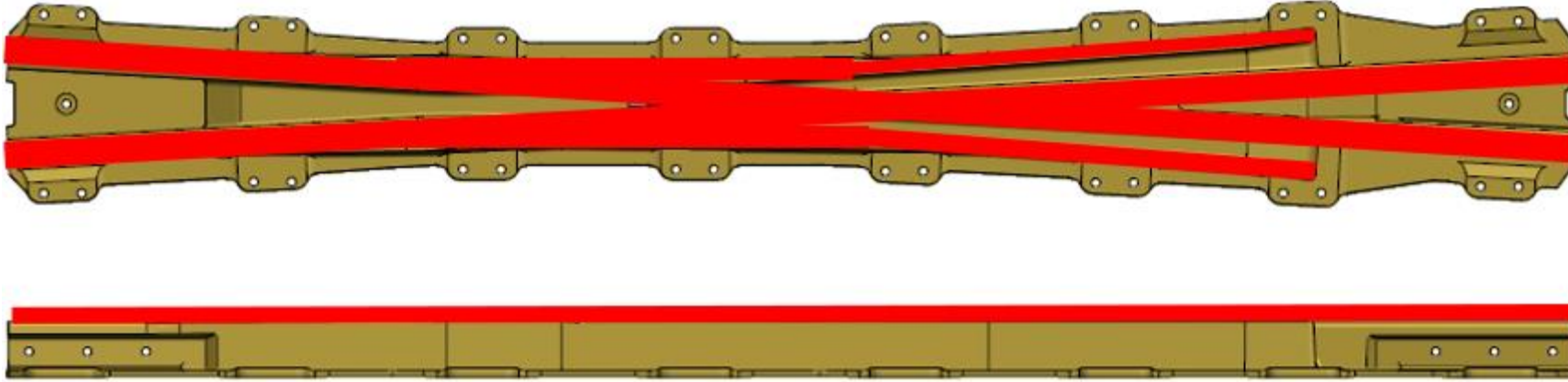

Roughing operation at 1/8 humpback slope and finishing at 1/8 slope

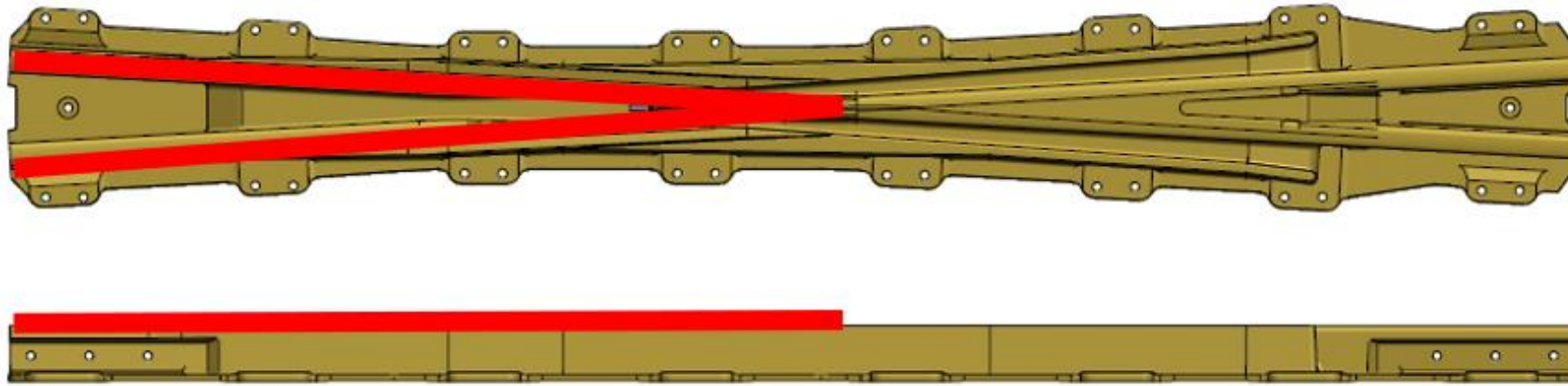

Milling operation for bearing groove slope 1/20

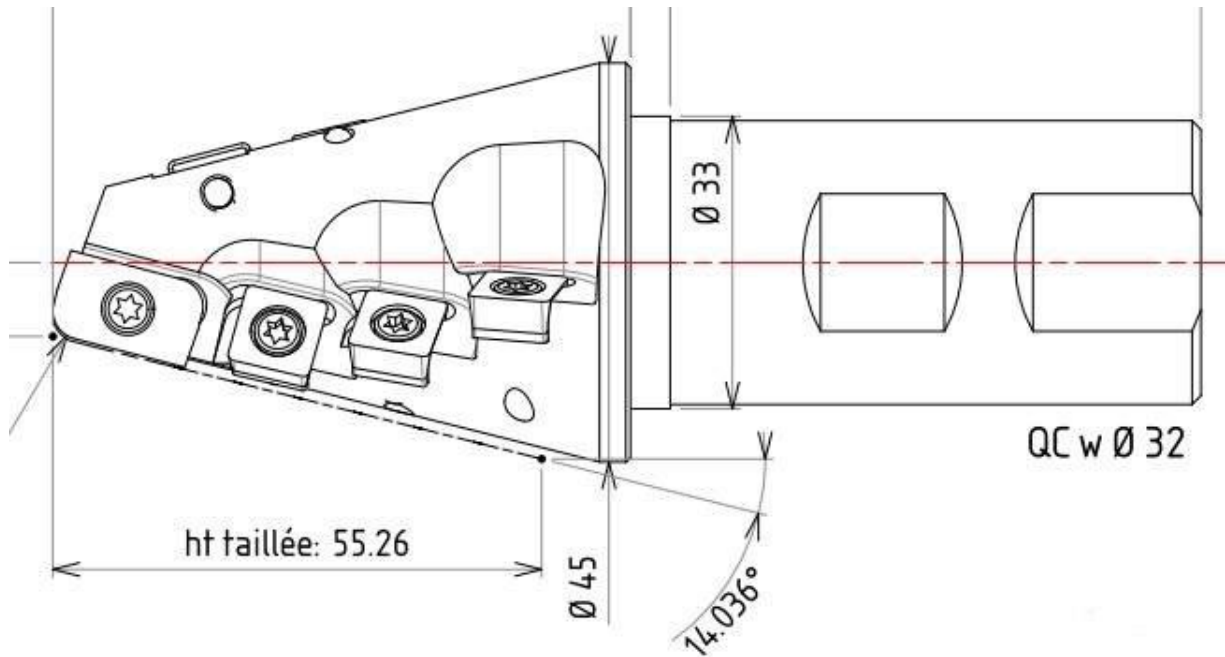
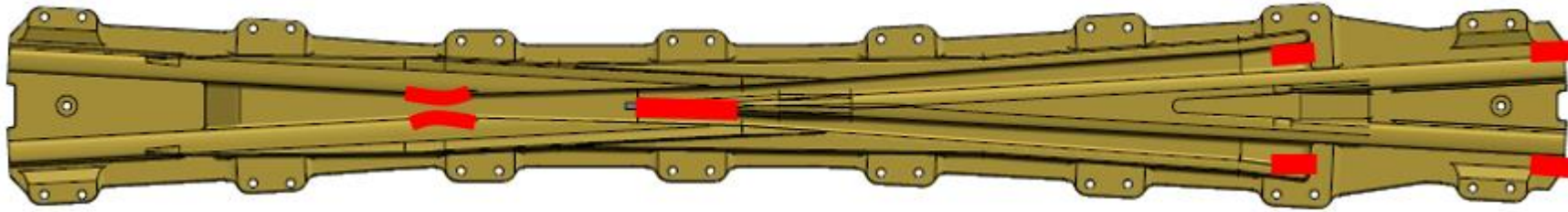

Milling operation on the tip and the left/right bearing section with a diabolo cutter

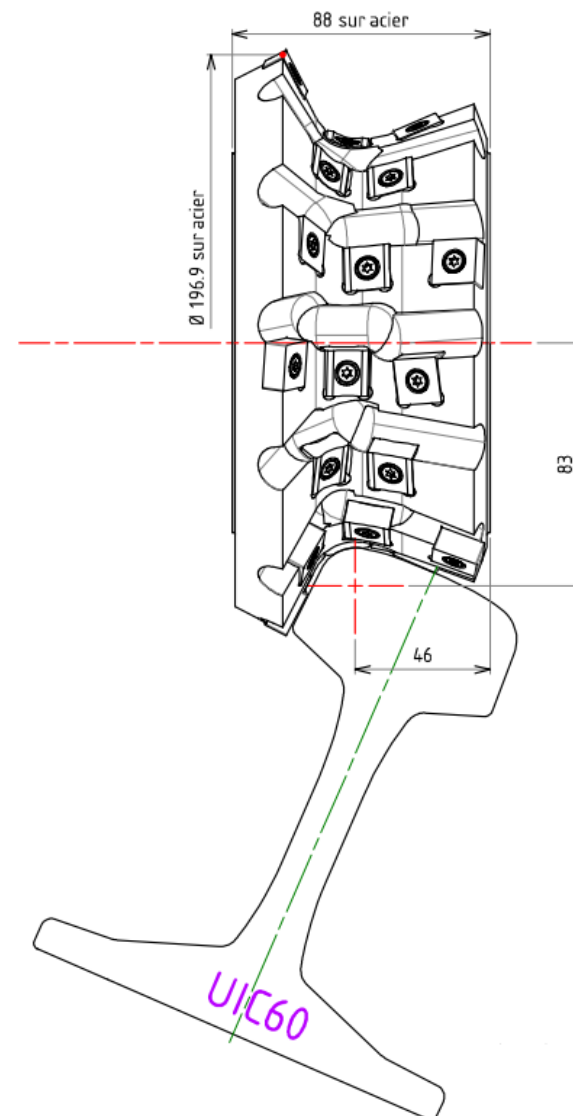
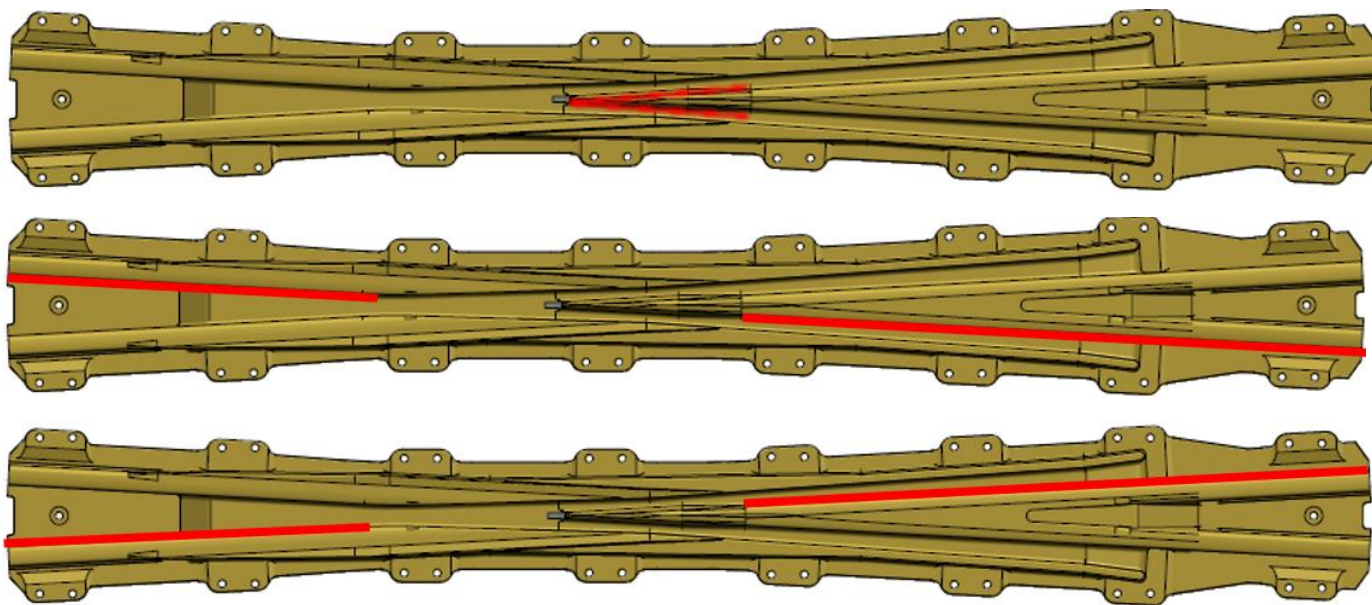

Internal and external splice milling operation with splice milling cutters

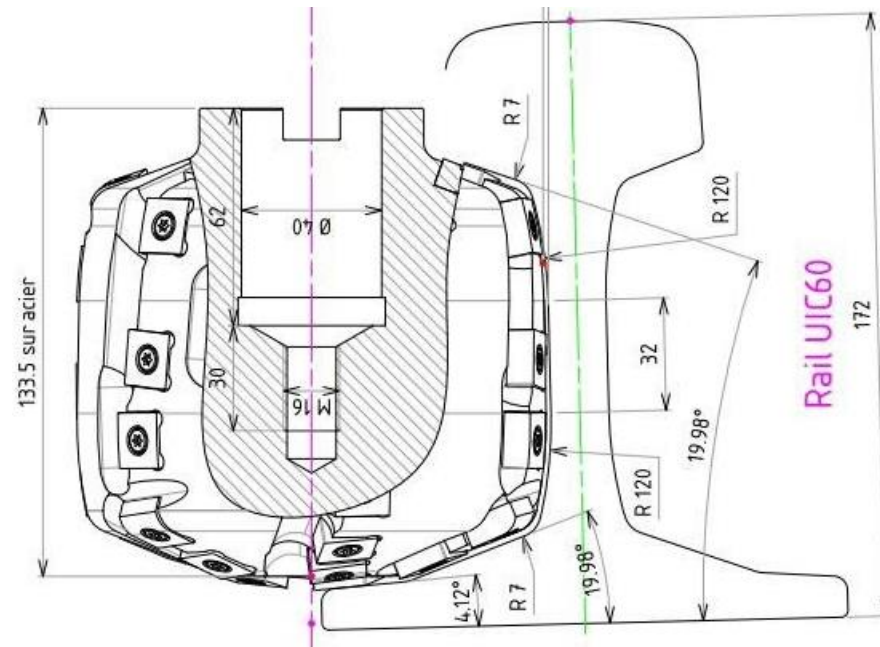
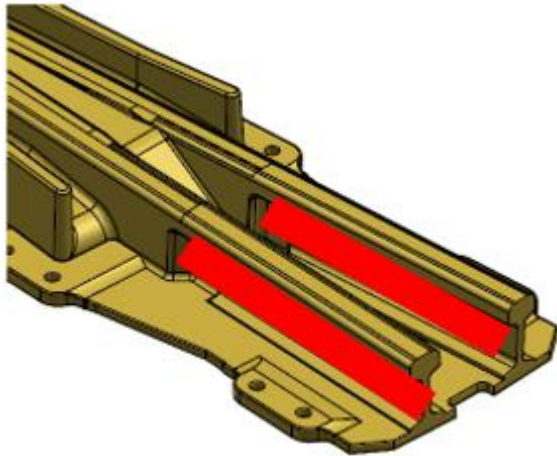
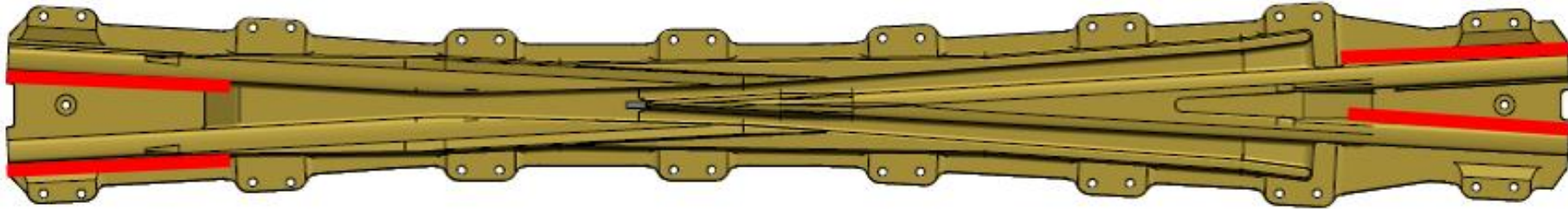

Drill operation of the fixing holes

